



GULF BAGS COMPANY
FOR PLASTIC INDUSTRY

رؤية
2030
المملكة العربية السعودية
KINGDOM OF SAUDI ARABIA

DISCOVER

**ENGINEERED FIBCs
SOLUTIONS FOR BULK
PACKAGING**



A leading supplier of high-quality, world class premium FIBC solutions.



PRODUCTS BROCHURE

2026

ABOUT US

A leading supplier of high-quality, world-class premium FIBC solutions.

Gulf Bags Company (GBC) is a specialized manufacturer and reliable expert supplier in FIBCs (Jumbo Bags), offering high-performance bulk packaging solutions for industries such as chemicals, minerals, construction, agriculture, food, plastics and fertilizers. With a strong commitment to quality, reliability, and innovation, GBC uses advanced manufacturing technologies and premium polypropylene materials to produce durable products that meet international standards. Our solutions are engineered to withstand demanding storage and transportation conditions while ensuring safety and efficiency. We provide a wide range of FIBCs (Jumbo Bags) in various sizes, designs, and specifications, including standard, conductive, and anti-static options. In addition, we offer customized printing and tailored solutions to meet specific customer needs. At GBC, we are dedicated to delivering cost-effective, reusable, and sustainable packaging solutions while fostering long-term partnerships with our clients.

“ Vision

To be a globally recognized leader in FIBC solutions, known for excellence in quality, innovation, and sustainability. We strive to set new industry benchmarks through advanced manufacturing technologies, continuous improvement, and a strong focus on customer satisfaction. Our vision is to deliver reliable, high-performance packaging solutions that meet evolving global demands while building lasting partnerships and contributing to a more efficient and sustainable future.

“ Mission

- To manufacture world-class **FIBC** solutions that meet international quality standards.
- To drive continuous innovation through advanced technology and processes.
- To deliver efficient, reliable, and tailored packaging solutions.
- To support sustainability with durable and eco-conscious products.
- To foster lasting partnerships through trust, service excellence, and customer focus.

Key Focus Areas 2026 :



Expansion of FIBC & PP Woven Bag production capacity.



Customers served across key industries.



Product quality, safety, and performance enhancement.

2026 at a Glance

10+

Year Experience

125+

Happy Customers

9.8/10

Overall Rating

Why **Trust** → **Our** Company?



Superior Product Quality

High-strength, durable, and reliable bags produced in compliance with international standards.



Industry Expertise

Deep expertise in FIBCs (Jumbo Bag) manufacturing, delivering high-quality, innovative solutions tailored to diverse industry needs.

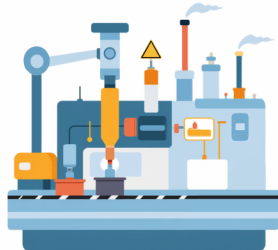

Advanced Manufacturing



Customized Solutions

Wide range of sizes, designs, and specifications tailored to meet unique customer needs.



On-Time Delivery

Strong supply chain and logistics support to ensure timely and reliable delivery.



Customer-Centric Approach

Building lasting partnerships through exceptional service, transparent communication, and unwavering commitment to customer success.

Various Options of Filling Designs

“From innovative manufacturing concepts to fully customized solutions, we offer a comprehensive range of FIBC bags designed to meet diverse industry needs and support your business expansion across global markets.”

Logistics | Handling | Distribution | Mobility | Flow | Transit | Storage | Durability

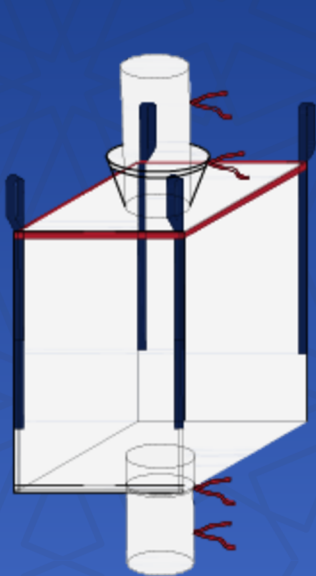

COVERED SPOUT TOP

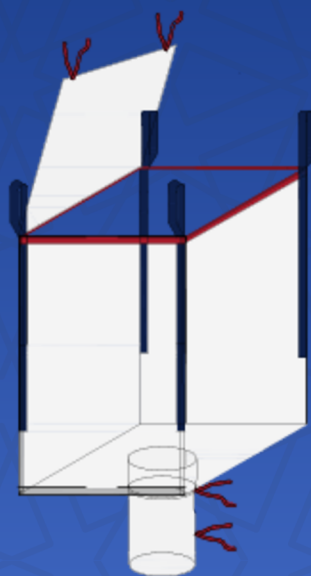

OPEN TOP WITH FLAP

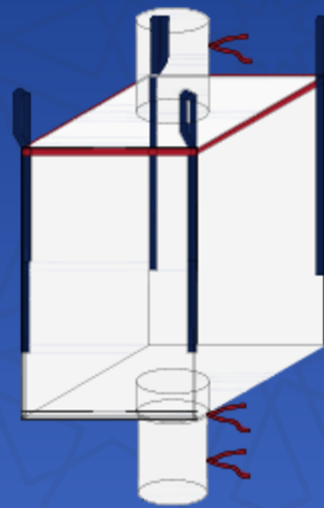

SPOUT TOP

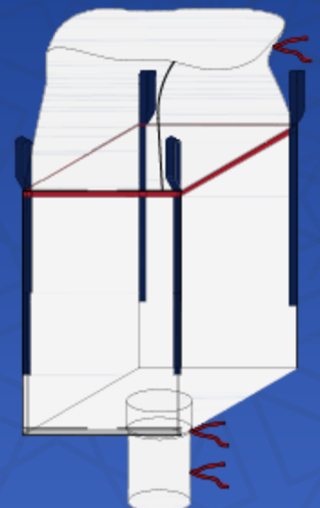

SKIRT TOP

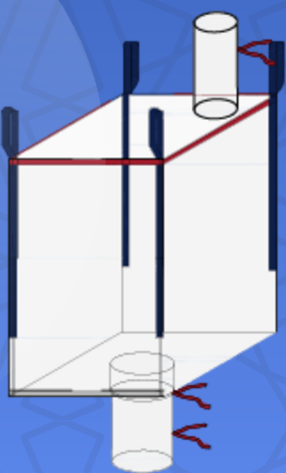

CORNER SPOUT

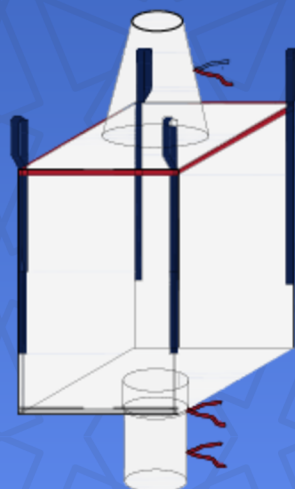

CONICAL SPOUT

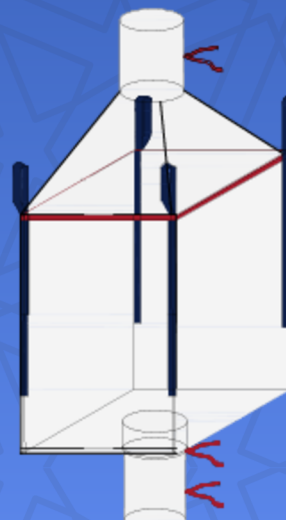

CONE TOP

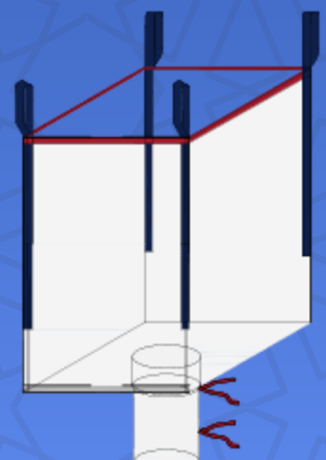

OPEN TOP

Various Options of Discharge Designs

Our FIBC bags are available with multiple filling options such as open top, filling spout, and duffle top designs, engineered to improve filling efficiency, reduce spillage, and accommodate various industrial applications.

Reliability | Performance | Strength | Precision | Consistency | Innovation | Stability

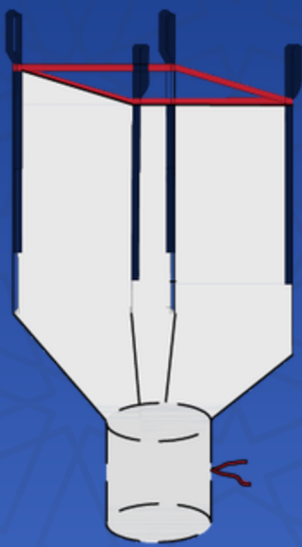

CONICAL BOTTOM



SPOUT WITH FLAP

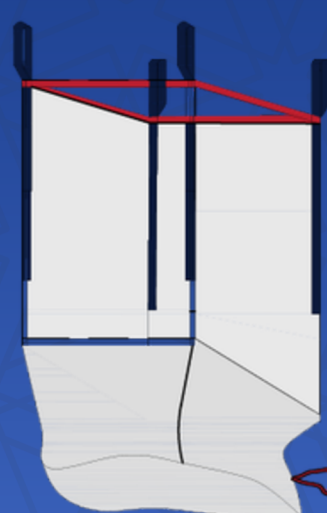

SKIRT BOTTOM

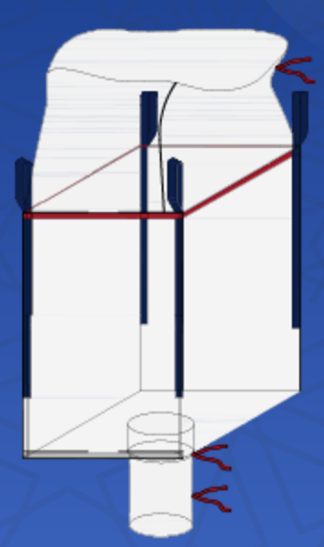

SPOUT BOTTOM

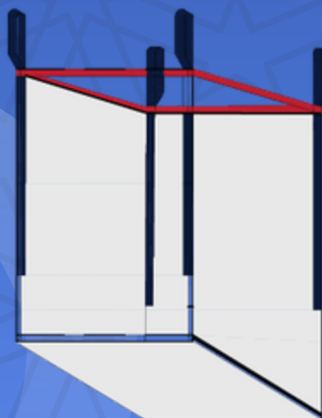

FLAT BOTTOM

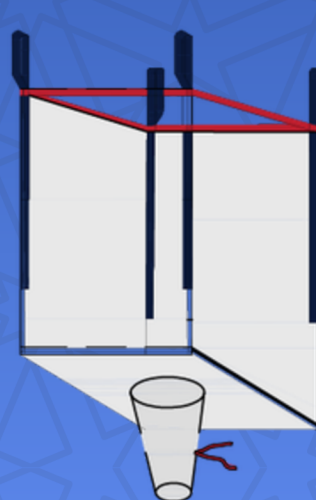

CONICAL SPOUT

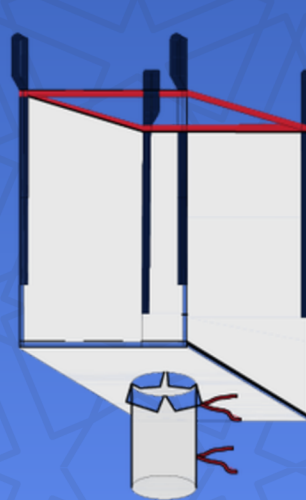

PETAL SPOUT

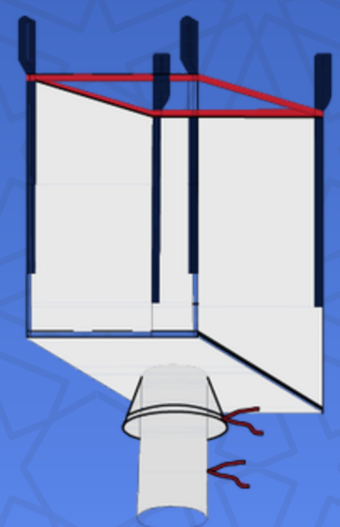

DRAWSTRING BOTTOM SPOUT

Various Options of Lifting Designs

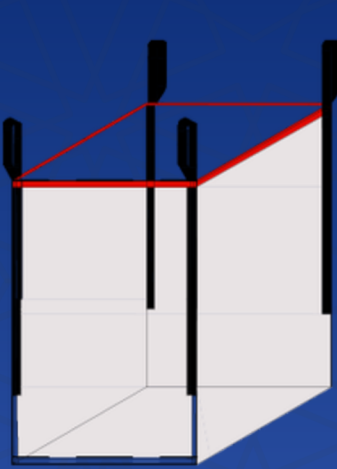

CORNER LOOP

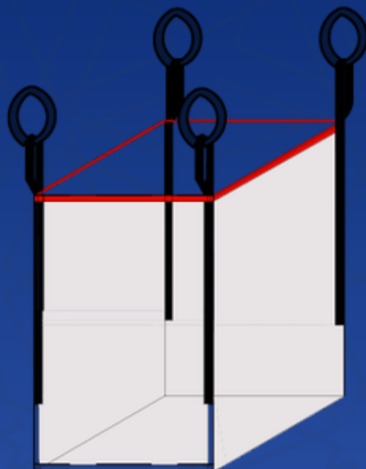

LOOP WITH EXTENDER
(ANCILLARY LOOPS)

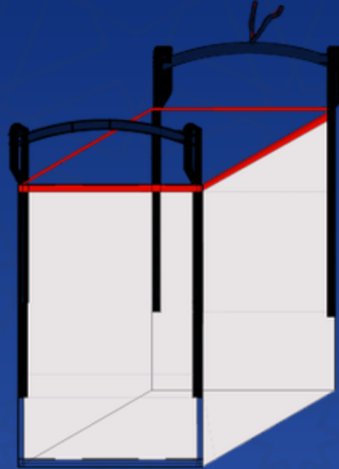

LOOP WITH STEVE-DORE

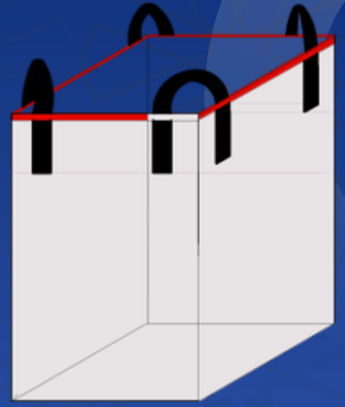

CROSS CORNER LOOP

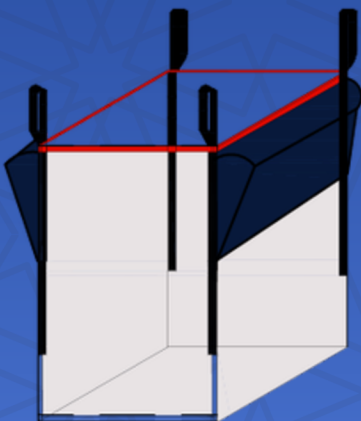

TUNNEL LOOP

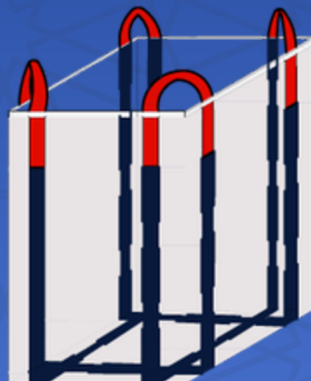

FULL LOOP

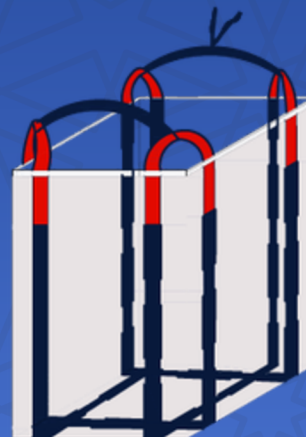

FULL LOOP WITH
STEVE DORE



ROPE LIFT BAG



ROPE STEVE DORE



TWO LOOP BAG

One-Stop
FIBC
Solutions

Closing & Gratitude

Thank you for taking the time to learn about Gulf Bags Company (GBC). We appreciate your interest in our FIBC and PP woven packaging solutions. We look forward to building a strong and successful partnership.

Contact Information

Contact

+966 54 403 7122
+966 56 023 3357

Website

www.gulfbagsksa.com

Instagram

[gulfbagsksa](https://www.instagram.com/gulfbagsksa)

Email

marketing@gulfbagsksa.com
info@gulfbagsksa.com

Address

Qasim Ibn Yaser Street ,
Light Industrial Area , Al
Jubail , Postal Code : 35521
Kingdom of Saudi Arabia

“
**Delivering
Strength
Ensuring
Safety
Building Trust**



**Let's build strength
into every load.**

A leading supplier of high-quality, world-class premium FIBC solutions.



Scan to visit